

Multivator



FPSR

FPSRXA



SAFETY PRECAUTIONS

READ THIS OPERATOR'S MANUAL CAREFULLY! Read and understand these safety precautions before operating the Multivator. Only responsible properly trained individuals should be allowed to operate the machine. The operator should be familiar with the controls, all safety precautions and all potential hazards.

Never allow children to operate the Multivator. Do not permit anyone to ride on the Multivator. Do not carry riders on the tractor.

OPERATION

- 1. Follow all safety decals on the machine. Keep them clean and replace them if they become worn and hard to read.**
- 2. Never leave tractor or Multivator unit running unattended.**
- 3. Do not modify the machine in any way unless authorized by Ford Distributing, Inc. Unauthorized modifications to the machine could result in machine damage and/or personal injury.**
- 4. Keep the operating area clear of all persons – particularly small children and pets. Inspect the operating area before using the Multivator and remove any obstacles which could damage the machine, or become entangled in the blades.**
- 5. Use only attachments or accessories designed for your Multivator.**
- 6. Do not operate the Multivator without all guards, shields and other safety devices correctly installed.**
- 7. Never use an unshielded PTO shaft, and always attach the shield retainer chain to the tractor or Multivator.**
- 8. Do not allow bystanders behind the Multivator when in operation. Rocks may be thrown to the rear.**
- 9. Do not operate the universal drive joint at an angle greater than 35°, or vibration and damage could result.**
- 10. Do not till across the face of slopes. Use extreme caution when turning on slopes.**



SAFETY PRECAUTIONS

- 11. Operate the Multivator only when you have good visibility. Make sure your feet are properly placed on the footrests and keep a firm grip on the steering wheel.**
- 12. Be careful not to touch tractor or Multivator parts which may be hot from operation. Allow parts to cool first.**
- 13. Whenever leaving the tractor and Multivator unattended, disengage the PTO, shift into neutral, set the parking brake, lower the machine, stop the engine and remove the ignition key.**
- 14. Always disengage power to the Multivator when transporting or when not in use.**

MAINTENANCE AND STORAGE

- 1. Never adjust, clean, repair or grease the Multivator or tractor with the tractor engine running. Stop the engine, disengage the PTO and remove the ignition key whenever you are not at the operating controls.**
- 2. Do not crawl under the Multivator when it is in a raised position. Never rely on tractor hydraulics to hold the machine in a raised position. Always provide support with blocks before adjusting, cleaning, repairing or greasing the machine.**
- 3. Check tightness of bolts, nuts, spring pins and clip pins frequently to ensure a safe working condition.**
- 4. Follow the daily lubrication and periodic maintenance procedures as described in the Operator's Manual.**
- 5. When storing the Multivator, make sure it is securely blocked in a safe, level position.**
- 6. Follow proper maintenance and repair schedules to keep unit in safe working order.**
- 7. Always use proper protective equipment when working on unit.**



SPECIFICATIONS

POWER RANGE

- **FPSR/FPSRXA: 50-150 PTO Horsepower**

TRACTOR REQUIREMENTS

- **540 RPM standard rotation (Optional 1,000 RPM Gearbox)**
- **PTO Category I or II three point hitch**

TRANSMISSION

- **By shielded PTO shaft assembly to single speed gearbox for use with 540 RPM tractor PTO.**
- **Friction disc slip clutch is available for extremely rugged or stony conditions.**
- **Input shaft on Multivator gearbox is 1-3/8" 6 spline.**

FINAL DRIVE

- **Power to rotor and blades is by heavy duty roller chain in sealed oil bath drive case assembly.**
- **FPSR/FPSRXA use 100H (20B) equivalent chain**

ROTOR AND BLADES

- **Multivator heads are equipped with four blades per flange.**
- **Blades are forged from chrome alloy steel, heat treated and shaped to take minimum power with maximum tillage ability.**

DEPTH CONTROL

- **The frame height is controlled by front mounted gauge wheels.**
- **Depth is controlled by adjusting the gauge wheel height via the screw jack assembly.**
- **Spring tension on the tillage heads provides positive down pressure to keep tillage heads at maximum depth while allowing the heads to float over undulations and stones.**
 - o **In hard soil conditions, spring tension may be increased to provide more down pressure.**
 - o **In stony conditions spring tension may be eased to allow for more flotation.**

GROUND SPEED

- **Ground speed is governed by power and soil conditions.**
 - **Hard ground will require lower travel speeds to maintain smooth operation.**



SPECIFICATIONS

- **Good ground conditions with reasonable moisture will allow travel speeds of 4-5 mph.**
- **Light ground conditions, shallow cultivation or a second pass will allow travel speeds of 5-6 mph.**

OPTIONAL FERTILIZER KIT

- **Dry granular fertilizer capacities:**
 - **40" hopper – approximately 350 lbs.**
 - **60" hopper – approximately 500 lbs.**
 - **80" hopper – approximately 650 lbs.**
- **Sufficient downspouts are provided to allow for multiple row requirements. Fertilizer drive is by 2 V-belts and 3 pulleys. Drive pulley is mounted to same hexagonal shaft which power tillage heads.**

ROTOR SPEEDS AT 540 RPM PTO SPEED

- **FPSR/FPSRXA 312 RP**

Blade Configuration FPSR/FPSRXA

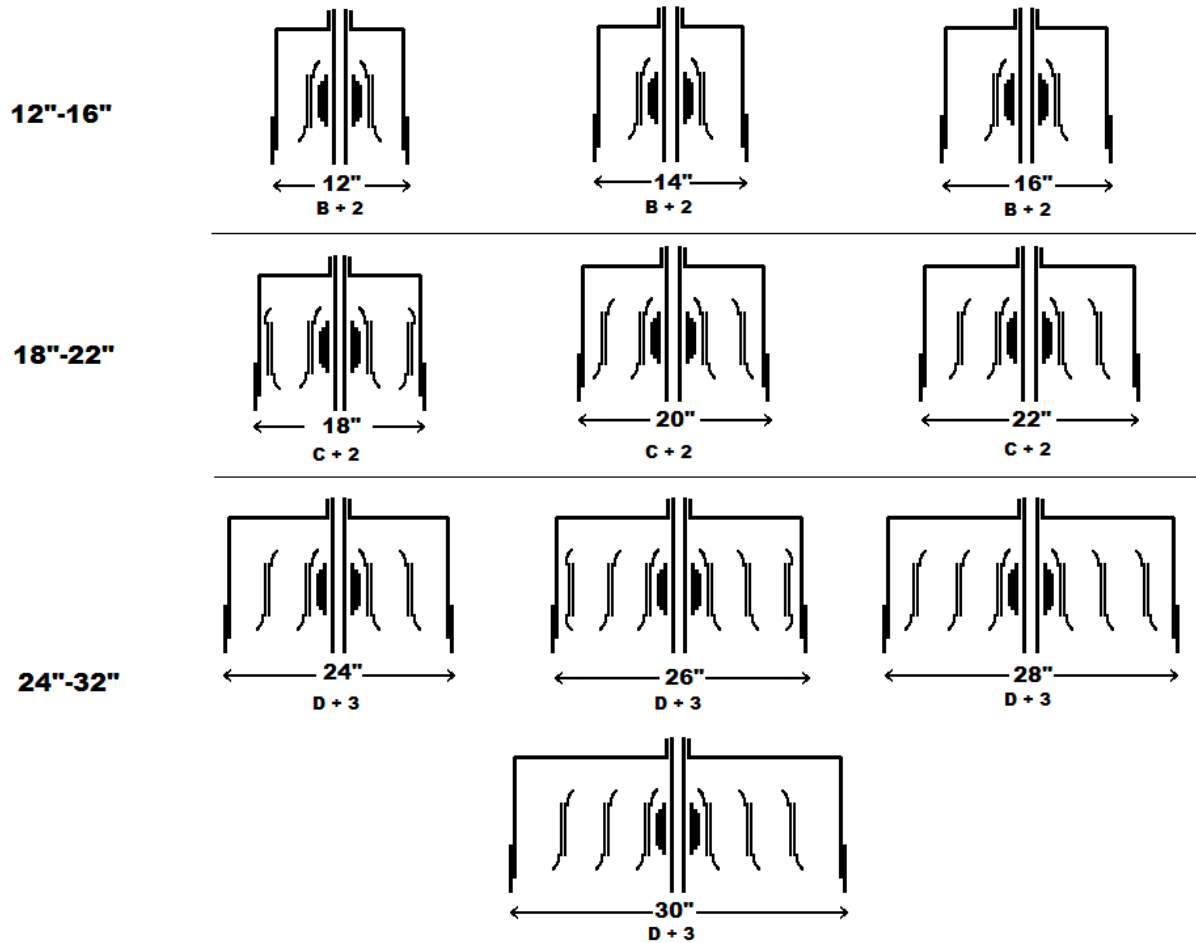

REFERENCE	PART NUMBER	DESCRIPTION
B	M420160005	Narrow center shield
C	M420160006	Medium center shield
D	M420160007	Wide center shield
2	M520162005	Medium side shield R.H.
	M520164005	Medium side shield L.H.
3	M520162006	Wide side shield R.H.
	M520164006	Wide side shield L.H.

MOUNTING MACHINE TO TRACTOR

1. Ensure that the tractor PTO is set for 540 rpm.
2. Stabilizers must be used on 3 point hitch arms to limit side sway.
3. A lift stop must be fitted to the hydraulic lift lever to prevent over lifting of the Multivator while in operation.

When lifting the Multivator during normal operation, ground clearance of 6-8" under the blades is completely adequate. Under no circumstances should the Multivator be raised to the point where damage to the universal joints on the PTO shaft occurs.



Never operate the machine with the universal joints at an angle greater than 35°. Excessive wear and damage will result!



4. Back the tractor up to the hitching points on the Multivator. Stop a few inches away and set the tractor hitch arms to the height of the Multivator hitch pins. Shut off the tractor engine.
5. Remove the split pins. Roll Multivator into position and insert the hitch arms into the pins. Reinsert split pins to lock pins into position. If machine is equipped with removable hitch pins, pins must be removed before fitting the tractor arms into position.
6. Position tie rod as shown above. Connect tie rod to machine from tractor's third point. Rotate adjustment handle in either direction until machine is in a level position. Adjust the tractor top link so that the Multivator frame is tilted to the rear approximately 5° from vertical. This ensures that the leading edge of the tiller shield is higher than the trailing edge and will not plow into the ground. Make this adjustment with the machine resting on the ground.
7. Connect the PTO shaft assembly to the Multivator gearbox input shaft (H). Connect the other end of the PTO shaft assembly to the tractor PTO shaft. Ensure that the quick disconnect pins snap into place on both shafts.



At this point you may have determined that the PTO shaft assembly needs to be shortened. If you can connect the PTO shaft to the tractor and Multivator without shortening it, you must ensure that the PTO shaft will not bottom out during operation. This may occur when raising or lowering the Multivator. If the shaft bottoms out during operation; damage may occur to the PTO shaft assembly, Multivator gearbox, and the tractor PTO.



Following are 2 techniques for measuring the correct length of PTO shaft:

- A. With the Multivator attached to the tractor, measure the horizontal distance from the input shaft on the gearbox to the tractor PTO shaft. Place the fully closed PTO shaft assembly on the ground and measure its overall length. If the PTO shaft assembly is shorter than the distance between the tractor PTO shaft and gearbox then you should not have to shorten it. If it is longer, then subtract the shorter measurement from the longer measurement. Add 1” to the difference. The result is the excess length that will need to be removed from each half of the PTO shaft assembly.**

- B. With the Multivator attached to the tractor, separate the PTO shaft assembly into two halves and attach one half to the tractor and one half to the Multivator. Hold each half alongside each other and determine the excess length of each half of the PTO shaft assembly.**

PROCEDURE FOR CUTTING THE PTO SHAFT:

- 1. Separate the PTO shaft into two halves.**
- 2. Using the measurement obtained above, shorten the plastic guarding using a hack saw.**
- 3. Using a chop saw, or a hack saw, shorten the steel profile tube by the same amount.**
- 4. Cut each half of the PTO shaft. 5. De-burr the profile tubes.**
- 5. Grease and reassemble the PTO shaft.**

PRE-WORK INSPECTION

- **Before using your Multivator, perform the following checks and services each day. (See Maintenance section for further details.)**
 - **Check gearbox for sufficient oil. If oil is to be added, use SAE 140 EP gear oil.**
 - **Grease the PTO shaft sliding sections and universal joints.**
 - **Grease the gauge wheel axles.**
 - **Remove any trash or material wrapped around the rotor or the rotor bearing covers.**
 - **Check for loose blades. Tighten any blade bolts as necessary. Loose blade bolts can lead to broken blades.**
 - **Check all bolts on machine for tightness.**

SETTING DEPTH

- **Cultivation depth is controlled by raising or lowering the gauge wheels on the front of the tool bar.**
- **With the Multivator attached to the tractor, and with the blades resting on the ground, raise the gauge wheels to the desired cultivation depth.**
- **Typically, this will be between 1” and 4” deep.**

WORKING

- **Start the tractor engine and lift the Multivator clear of the ground. Six to eight inches should be sufficient height to lift the machine. Proceed to the work site and position the tractor for the first run.**
- **Engage the tractor PTO, select a low gear, and move ahead slowly lowering the Multivator into the ground. Use at least $\frac{3}{4}$ throttle when starting and increase to rated engine speed at 540 PTO rpm as the Multivator sets into the soil.**
- **The Flow Rate Control Knob for the tractor hydraulics may need to be set to the “Slow” position to ensure gentle lowering of the machine into the ground.**
- **Also make sure that the three point hitch is set in the “Float” position. After a short working distance, stop the tractor and check your work to see that desired results are being obtained.**

RUNNING IN

- **For the first 10 hours of operation, run the Multivator easily. Do not allow the Multivator to lug the tractor down. Check the temperature of the gearbox and chaincase units to ensure that they are not operating at**

excessive heat levels. High temperatures can be an indication of a potential problem with a component, low oil levels, or possibly an assembly problem.

GROUND SPEED

- Ground speed is governed by power and soil conditions. Hard ground will require lower travel speeds to maintain smooth operation. Good ground conditions with reasonable moisture will allow speeds of 4-5 mph. Light ground conditions, shallow cultivation, or a second pass will allow travel speeds of 5-6 mph.

ENGINE RPM

- Try to operate at the rated engine speed to achieve 540 RPM PTO speed. Allowing the tractor to lug down continuously can result in damage to the tractor and the Multivator.

SOIL TILTH CONTROL

- Tilth is governed by forward speed and engine RPM. Slower forward speeds will give the finest possible finish. Higher forward speeds will give a cloddier or rougher finish.

HEADLAND PROCEDURE

- Each time the headland is reached, lift the machine clear of the ground (6" to 8" maximum). With the blades rotating, turn the tractor for the next pass, and slowly lower the machine into the ground.

****DO NOT TURN THE TRACTOR WITH THE MULTIVATOR IN THE GROUND!****

WORKING LIMITATIONS

- It is very important that the Multivator be used in conditions that will not obviously damage the machine. The Multivator has the ability to handle small stones and other obstacles by "walking over" these obstacles and kicking them out behind the machine. The forward rotating blades, and free floating heads, allow for this action to occur.
- Extremely rugged conditions will cause excessive wear and tear on blades, shielding, and working components of the machine, requiring more operator maintenance.
- If the blades do not penetrate the soil easily, and you cannot obtain more than 1" depth on a first pass with wheels clear of the ground, conditions may be too dry and hard. Continued use of the Multivator in

such conditions will cause excessive wear on the drive train and will void any warranty consideration.

- If considerable vibration, jumping, and shock loading is apparent, then the conditions are not suitable to work in.
- If these conditions are unavoidable, then please adhere to the following guidelines:
 - Try to irrigate, or wait until adequate soil moisture is present
 - Use another tillage tool, such as a chisel shank or V-ripper, to relieve compaction before using the Multivator
 - Relieve spring tension on the tiller heads to allow them to float more easily over obstacles
 - Fit a safety clutch to the PTO drive line
 - Increase the frequency of machine inspections during operation
 - Be attentive to the machine and any potential problems, particularly loose blade bolts, broken blades, and high fluid temperatures in the gearbox and chaincases

ABRASIVE SOILS

- Use in very abrasive soils will significantly reduce blade life. These soils are sandy or gravelly in nature.
- Additional care should be taken to inspect the chaincase skid at regular intervals. The chaincase skid provides important protection to the chaincase, as well as eliminating the center untilled strip. The chaincase skid must be replaced when it is worn out.
- Optional chaincase wearing shoes are available from the manufacturer. These wearing shoes bolt to the underside of the chaincase and provide an additional wearing surface. They may provide additional protection in very abrasive conditions.

HEAVY TRASH CONDITIONS

- In very tall weed growth, tough grass tilling, corn residue, stalky or vine type weeds, care should be taken to avoid excessive weed wrap on the blades and rotors. After using the Multivator, clean any residue from the tilling blades, particularly between the inner blade flanges and the chaincase.
- If trash buildup is occurring on the shields, reposition the shields so they are angled down in the back and up in the front. This is accomplished by repositioning the brackets to which the shields are mounted.



OPERATION

- **If trash buildup is occurring on the center sweep, it may be necessary to remove the “wings” from the center sweep with a torch. The center sweep will then slice through the soil and trash. However, it should be remembered that removing the wings from the center sweep will reduce the effectiveness of the sweep for weed removal.**

MAINTENANCE

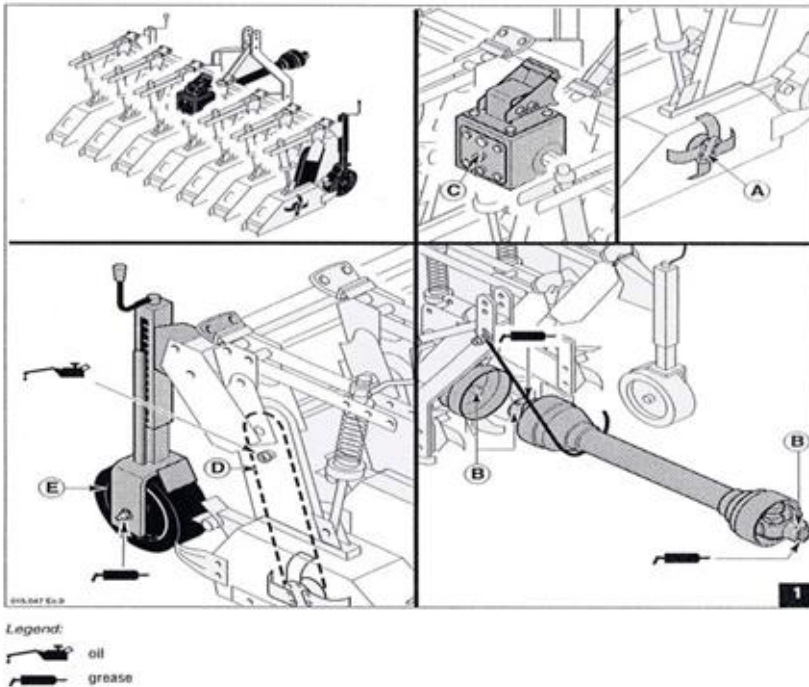

After initial running period, (approximately 25 hours) drain the gearbox oil and replace. Some discoloration of the oil is normal.

On a monthly basis check the oil level in all chaincases. Remove fill plug to access oil level. Refill all that are necessary with SAE90 gear oil.

DAILY	
Blades (A)	Check for loose bolts and retighten.
Blade bolts, rotor bolts, flange bolts, shield bolts, clamp plate nuts	Check for loose bolts and retighten.
PTO universal joint bearings (B)	Grease universal joints and sliding sections of PTO shaft with quality grease.
Wheel bearings (E)	Grease with quality grease.

WEEKLY	
Gearbox (C)	Check oil level. Refill if necessary with SAE140EP.
PTO shaft	Clean shaft and check bearings.
Complete Machine	Clean machine for thorough inspection. Check all miscellaneous bolts and nuts to ensure tightness.
Chaincase	Check wearing skids and replace any worn skids as necessary.

CHAIN ADJUSTMENT

- **On models FPSR and FPSRXA there is an adjustment screw located on the front of the chaincase in order to tension the chain.**

CHAINCASE LUBRICATION

- **Each chaincase is supplied fully lubricated. Over time, lubricant will need to be replaced, and periodically the chaincase may need to be completely flushed and refilled.**
- **Adding lubricant is done through the breather – fill plug located on the side of the chaincase. Chaincases should be filled approximately 1/3 full with good quality SAE90 gear oil. If too much oil is added to the chaincase you will notice oil escaping from the breather plug in a fine mist.**
- **Another method of lubricating the chaincase is to pack the case completely with grease. This can be done when renovating old chaincases with worn components, as the grease helps to seal the chaincase from dirt.**

ROTOR MAINTENANCE

- **Remove flanges and draw bolt(s) on a yearly basis, preferably before the initial use for the season. Remove all foreign debris that has accumulated on flanges, blades, rotor, and dust covers. Inspect all flanges, draw bolts, metal dust covers, and oil seals. Replace any and all items with excessive wear. Be sure that oil seals are intact and not leaking chaincase oil.**



TROUBLESHOOTING

PROBLEM	DIAGNOSIS
PTO shaft vibrates or chatters	Check for worn cross and bearing kits. Pay attention to lift height when machine is in use. Lifting machine too high puts the PTO at angles causing premature wear.
Gearbox noise is noticeable or constant.	Check oil level in gearbox. Make sure nothing is obstructing moving components tied to gearbox.
Intermittent clicking noise from rotors, chaincase or gearbox.	Check for loose blades. If noise persists check gearbox for damage to pinion gear or ring gear teeth. Clicking noises inside chaincase can indicate a worn chain skid. Replace as necessary.
Slapping noise from chaincase	Chain is too loose. If chain is worn it should be replaced or shortened if possible.
Hex drive shaft is rotating but blades are not.	This indicates a broken chain link inside the chaincase, broken or rounded off draw bolt.
Burning smell, or signs of excessive heat	Usually caused by rotors which are not turning freely. Check for trash wrapped around rotor, especially between inner rotor and dust cover.
Blades won't penetrate average soil conditions	Check that blades are installed correctly. Blades or complete flange may have been installed backwards
Machine skips or does not cut all weed residue.	Check for worn blades. If blades are worn down to a sharp point, overlap will be lost and cutting ability will deteriorate. Replace worn blades
Burning smell, or signs of excessive heat	Check for bent flanges or a bent draw bolt.

No	Part Number	Qty	Description
1	M420610060	2	Center Upright
2	M420610074	1	3-point Mini Top Tube
3	M350770012	2	Tube Clamp Plate
4	M103150128	4	Bolt M16 x 55 Plated
5	M103040072	4	M16 Locknut
6	M103120007	2	Tube Plug
7	M420680015	1	Tie Rod for Hitch
8	M103150098	1	Bolt M14 x 35 Plated
9	M103040070	1	M14 Locknut
10	M103040034	6	Nut M16 x 2.00
11	M330770006	2	5 Hole Clamp Plate
12	M101070002	2	Lynch Pin
13	M310560015	2	Hitch Pin Cat I

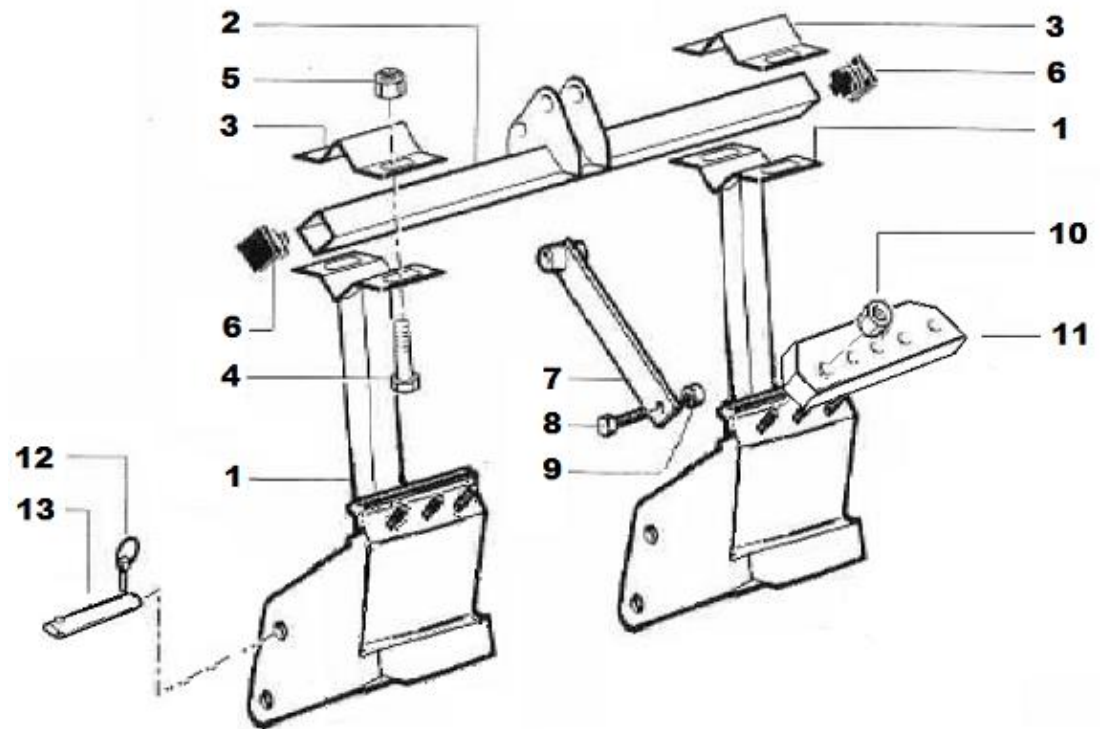

FP/FPSR 3 POINT HOOK UP

90" FRAMES AND NARROWER

FP/FPSR 3 POINT HOOK UP

132" FRAMES AND WIDER

*See picture below for details

No	Part Number	Qty	Description	
1	M420610060.01	2	Reinforced Center Upright	
2	M420610059	2	Outer Upright	132" – 192" Frame
		4	Outer Upright	240" Frame
3	M420610061	1	3-Point Wide Top Tube	132" – 192" Frame
	M420610061.01	1	3-Point X -Wide Top Tube	240" Frame
4	M350770012	4	Tube Clamp Plate	132" – 192" Frame
		6	Tube Clamp Plate	240" Frame
5	M103040072	8	M16 Locknut	132" – 192" Frame
		12	M16 Locknut	240" Frame
6	M103150128	8	Bolt M16 x 55 Plated	
	M103150131	12	Bolt M16 x 80 Plated	
7	M103120007	2	Tube Plug	
8*	M420680015	1	Tie Rod for Hitch	132" Frame
	M420680046	1	Reinforced Tie Rod for Hitch	180" – 192" Frame
	M420680046.01	1	Long Reinforced Tie Rod for Hitch	240" Frame
9	M103150098	1	Bolt M14 x 35 Plated	
10	M103040070	2	M14 Locknut	
11	M103150109	1	Bolt M14 x 100 Plated	
12	M101070002	2	Lynch Pin	
13	M320560016	2	Hitch Pin Cat II	
14	M103040034	10	Nut M16 x 2.00	132" – 192" Frame
		14	Nut M16 x 2.00	240" Frame
15	M330770006	2	5 Hole Clamp Plate	



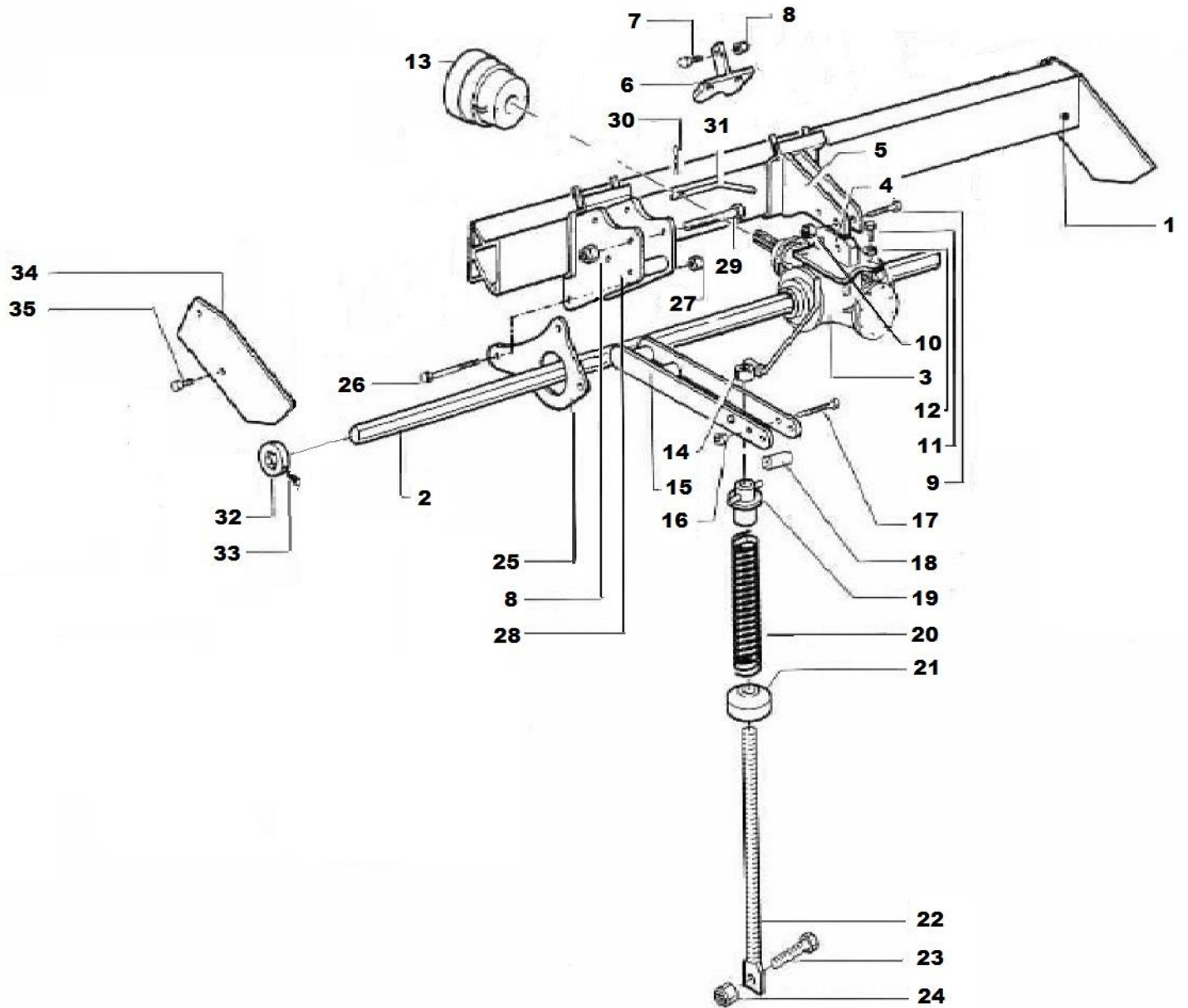

FPSR FRAME

**** 240" FRAME ASSEMBLY NOT SHOWN***

FPSR FRAME

No	Part Number	Qty	Description
1	M420650009	1	66" Toolbar
	M420650011	1	90" Toolbar
	M420650128	(1)	90" Reinforced Toolbar (optional)
	M420650015	1	132" Toolbar
	M420650130	1	180" Toolbar
	M420650131	1	192" Toolbar
	M420650148	1	240" Toolbar
2	M320080031	1	66"; 51mm Hex Bar
	M320080032	1	90"; 51mm Hex Bar
	M320080033	1	132"; 51mm Hex Bar
	M320080034	1	180"; 51mm Hex Bar
	M320080037	1	192"; 51mm Hex Bar
3	M112050050	1	FPSR 50mm 540 RPM Gearbox; TB22C
	M112050051.02	1	FPSR 50mm 1,000 RPM Gearbox; R115
4	M420610010	1	Lower Support Bracket
5	M420610009	1	Upper Gearbox Support Bracket
6	M420600002	1	T-Clamp Plate
7	M103150109	1	Bolt M14 x 100 Plated
8	M103040070	1 + X	M14 Locknut
9	M103150081	2	Bolt M12 x 60 Plated
10	M103040068	2	M12 Locknut
11	M103150120	4	Bolt M16 x 25 Plated
12	M103100040	4	M16 Shakeproof Washer
13	M101010002	1	PTO Guard at Gearbox
14	M520130003	X	Handle With Nut
15	M420090002	X	Support Arm
16	M103040014	X	M10 Nut
17	M103150055	X	Bolt M10 x 90 Plated
18	M320210006	X	Spacer
19	M420490003	X	Spring Guide
20	M320470004	X	Spring Coil
21	M420120003	X	Spring Collar
22	M320820006	X	Threaded Rod
23	M103150044	X	Bolt M10 x 30 Plated
24	M103040066	X	M10 Locknut
25	M320570022	X	Chaincase Mounting Plate
26	M103150135	X	Bolt M16 x 140 Plated
27	M103040034	X	M16 Nut x 2.00
28	M420040002	X	Head Stock
29	M103150112	X	Bolt M14 x 110
30	M101020002	X	Pin Clip
31	M320410002	X	Pin
32	M320020004	2	Locking Ring 50mm
33	M103150034	2	Bolt M10 x 20
34	M320620006	2	Guard Plate
35	M103150066	4	Bolt M12 x 20 Plated
*	M320320011	2*	50mm Hex Bar Coupler (Not Shown)

*240" Hex Bar Consists of	
2 - M320080031 – 66" Hex Bar	
1 - M320080034 – 180" Hex Bar	
2 – M320320011 – 50mm coupler	
M520210012	FPSR Gearbox with mounting bracket
M520120019	Gearbox Mounting Kit
M520120019.01	Gearbox Mounting Kit for 1,000 RPM

"X" is equal to the number of heads on the toolbar. So if there are 2 heads then X=2

**FPSR
M520250014**

No	Part Number	Qty	Description
1	M500130004	1	Screw with handle
2	M420610086	1	Upper support
3	M420610088	1	Lower support
4	M320560030	1	Axle
5	M103090002	1	Grease zerk
6	M104010002	2	Bearing 6205Z
7	M420220010	1	Spacer
8	M103040072	1	Locknut M16
9	M420520002	1	Steel Tire (HD)
10	M103040034	2	Nut M16
11	M320770004	1	Clamp plate
12	M320210007	1	Spacer
13	M420220009	1	Spacer

**FPSRXA
M520250015**

No	Part Number	Qty	Description
1	M520130005	1	Screw with handle
2	M420610087	1	Upper support
3	M420610089	1	Lower support
4	M320560030	1	Axle
5	M103090002	1	Grease zerk
6	M104010002	2	Bearing 6205Z
7	M420220010	1	Spacer
8	M103040072	1	Locknut M16
9	M420520002	1	Steel Tire (HD)
10	M103040034	2	Nut M16
11	M330770006	1	5 Hole Clamp plate
12	M320210007	1	Spacer
13	M420220009	1	Spacer

**FPSR PNEUMATIC
M520250014.01**

No	Part Number	Qty	Description
1	M500130004	1	Screw with handle
2	M420610086	1	Upper support
3	M420610088.01	1	Lower support
4	M320560030	1	Axle
5	M103090002	1	Grease zerk
6	S600602	2	Bearing 6205-RS
7	M420220009	2	Spacer
8	M103040072	1	Locknut M16
9	M101050013	1	Rubber Tire
10	M103040034	2	Nut M16
11	M320770004	1	Clamp plate
12	S200415	1	Spacer

**FPSRXA PNEUMATIC
M520250014.02**

No	Part Number	Qty	Description
1	M520130005	1	Screw with handle
2	M420610087	1	Upper support
3	M420610088.02	1	Lower support
4	M320560030	1	Axle
5	M103090002	1	Grease zerk
6	S600602	2	Bearing 6205-RS
7	M420220009	2	Spacer
8	M103040072	1	Locknut M16
9	M101050013	1	Rubber Tire
10	M103040034	2	Nut M16
11	M330770006	1	5 Hole Clamp plate
12	S200415	1	Spacer

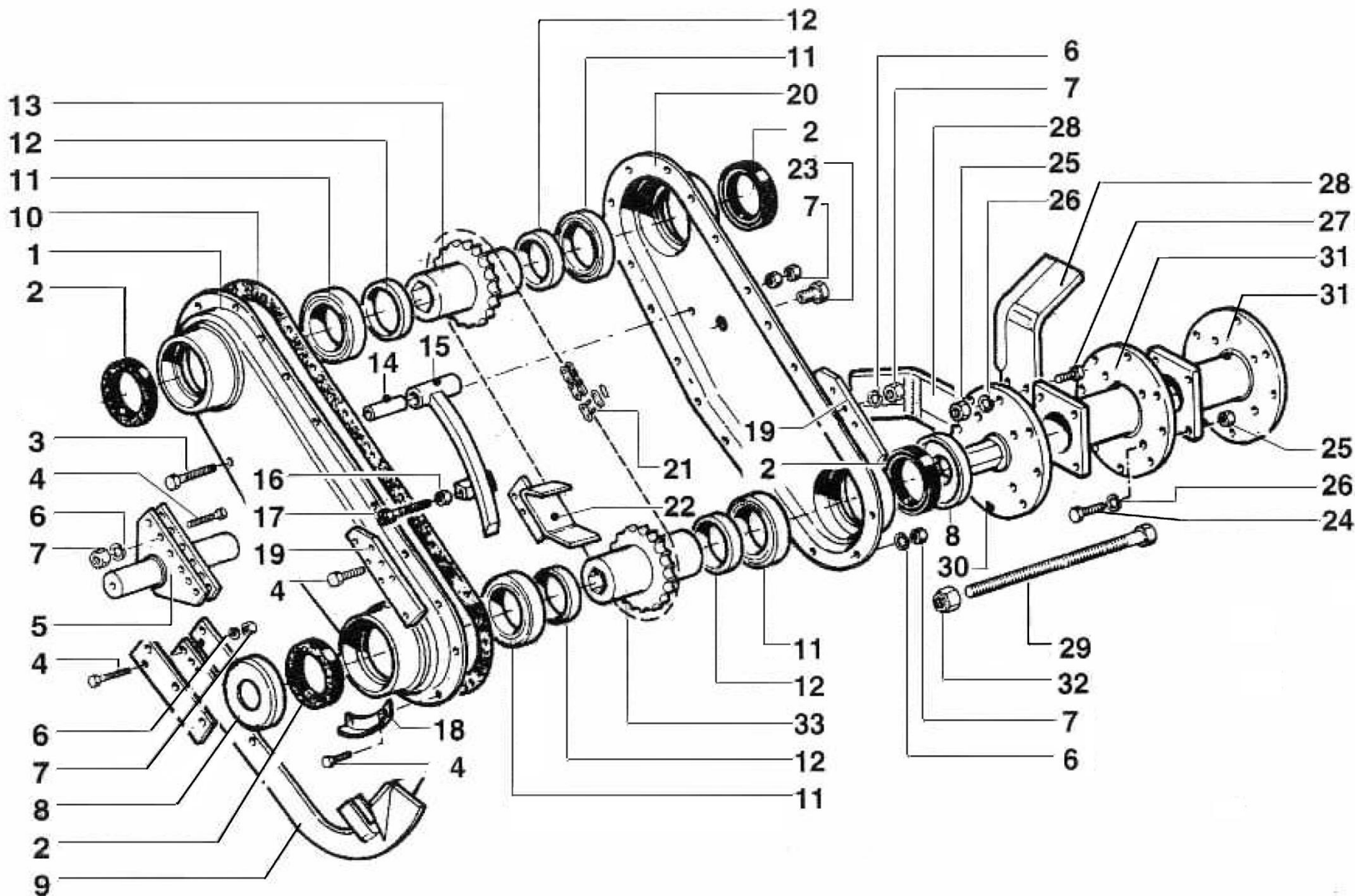

FPSR CHAINCASE ASSEMBLY

FPSR CHAINCASE ASSEMBLY

No	Part Number	Qty	Description
1	M420554008	1	Chaincase Half; Left / FPSR ~28"
	M420554010	1	Chaincase Half; Left / FPSRXA ~39"
2	M109040022	4	Oilseal 95 x 70 x 13
3	M103140034	1	Bolt M8 x 70
4	M103140026	10	Bolt M8 x 30
5	M420610008	1	Front Shield Support / FPSR
	M420610034	1	Front Shield Support / FPSRXA
6	M103100006	13	Washer M8
7	M103040064	23	Locknut M8
8	M320550004	2	Bottom Rotor Dust Cover
9	M420590003	1	Depth Skid FPSR
10	M320330003	1	Chaincase Gasket FPSR
	M320330005	1	Chaincase Gasket FPSRXA
11	M104010016	4	Bearing 6014
12	M320210031	4	Spacer
13	M320600006	1	Top Sprocket; 50mm
14	M320090009	1	Bushing
15	M420660011	1	Chain Tensioner FPSR
	M420660005	1	Chain Tensioner FPSRXA
16	M103040014	1	Nut M10
17	M103150200	1	Bolt M10 x 70 Full Thread
18	M320620050	2	Skid Protector
19	M320580002	2	Rear Shield Support FPSR
	M320580088	2	Rear Shield Support FPSRXA
20	M420552008	1	Chaincase Half; Right / FPSR ~28"
	M420552010	1	Chaincase Half; Right / FPSRXA ~39"
21	M112020034.01	1	Chain 1-1/4" x 42 Pitch ASA 100 / FPSR
	M112020030.01	1	Chain 1-1/4" x 60 Pitch ASA 100 / FPSRXA
22	M420030002	1	Rear Shield Support
23	M320800001	1	Fill Plug
24	M103140077	(8 * X)	Bolt M12 x 40x1.25 - 10.9
25	M103040024	16 + (12 * X)	Nut M12 x 1.25
26	M103100026	16 + (12* X)	Lock Washer M12
27	M103140074	16 + (8 * X)	Bolt M12 x 35 x 1.25 - 10.9
28	M111434-R	2	Standard Right Hand Blade FPSR
	M111434-L	2	Standard Left Hand Blade FPSR
	M111434C-R	(2)	Long Right Hand Blade FPSR (optional)
	M111434C-L	(2)	Long Left Hand Blade FPSR (optional)
29	M420680006	1	Drawbolt 11" Nominal Length/ FPSR
30	M420370011	2	Drive Flange FPSR
31	M420220004	X	Outer Flange FPSR
32	M103040078	1	Locknut M20 x 1.5
33	M320600007	1	Bottom Sprocket; 50mm FPSR
	M320600008	1	Bottom Sprocket; 50mm FPSRXA

M200056	Flange Bolt Assembly
M200058	
Blade Bolt Assembly	

"X" is equal to the number of Outer Flanges (M420370011). So with one outer flange on either side, X = 2.

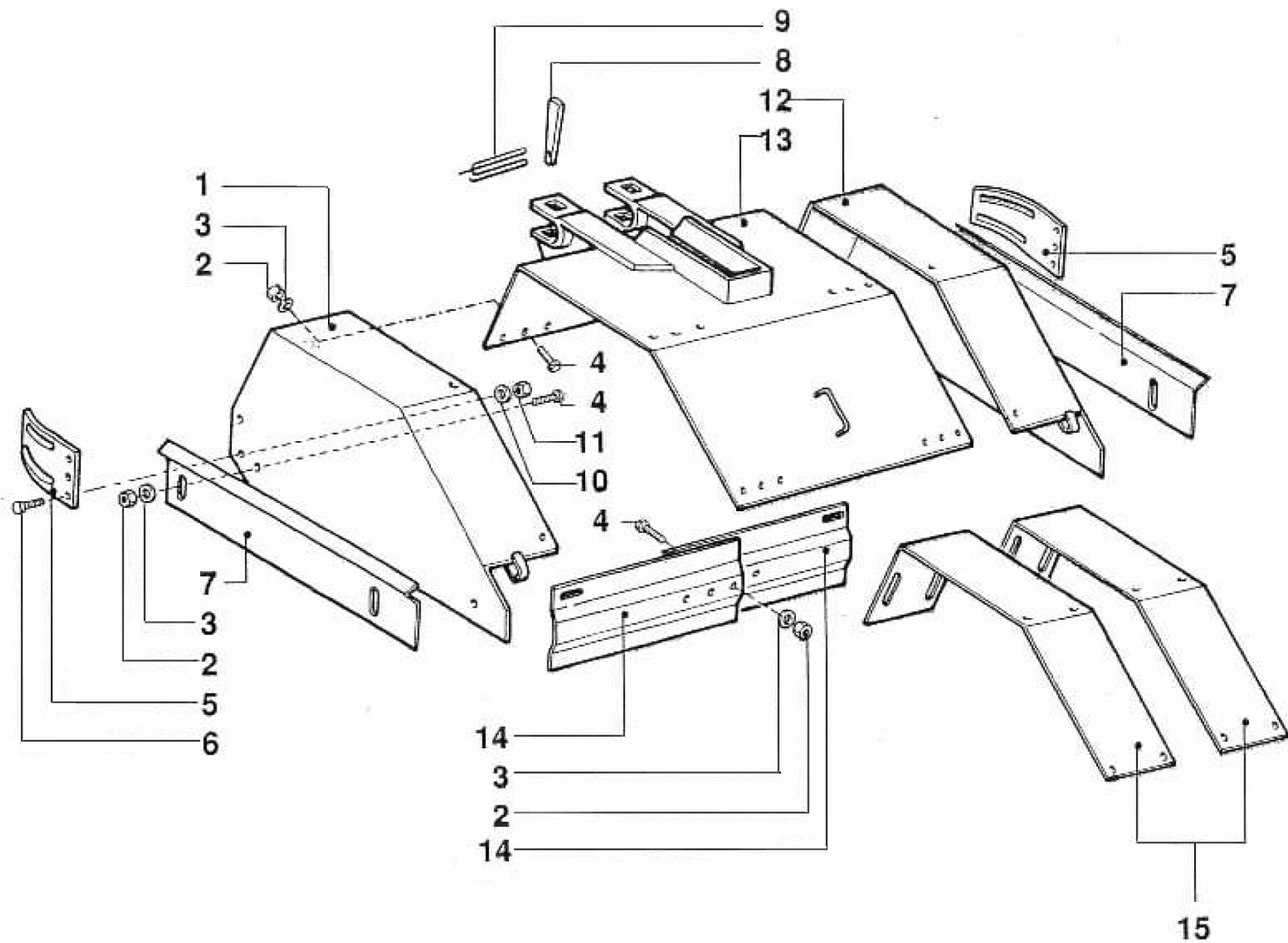

FPSR SHIELD ASSEMBLY

FPSR SHIELD ASSEMBLY

No	Part Number	Qty	Description	
1	M520164004	1	Left Narrow Side Shield Assembly (2.5" Wide)	Includes Side Shield Protector, Plant Guard, and hardware
	M520164005	1	Left Medium Side Shield Assembly (4.5" Wide)	
	M520164006	1	Left Wide Side Shield Assembly (6.5" Wide)	
2	M103040014	11	Nut M10	
3	M103100008	11	Washer M10	
4	M103150034	11	Bolt M10 x 20 Plated	
5	M300620001	2	Plant Guard	
6	M103150005	4	Bolt M8 x 16 Plated	
7	M320620016	2	Side Shield Protector	
8	M300740001	2	Wedge Pin	
9	M300470018	2	Spring Wire Clip	
10	M103100006	4	Washer M8 Plated	
11	M103040008	4	Nut M8	
12	M520162004	1	Right Narrow Side Shield Assembly (2.5" Wide)	Includes Side Shield Protector, Plant Guard, and hardware
	M520162005	1	Right Medium Side Shield Assembly (4.5" Wide)	
	M520162006	1	Right Wide Side Shield Assembly (6.5" Wide)	
13	M420160005	1	Center Shield for 12"-16" Heads (9- $\frac{3}{4}$ " Wide)	
	M420160006	1	Center Shield for 18"-22" Heads (15- $\frac{3}{4}$ " Wide)	
	M420160007	1	Center Shield for 24"-32" Heads (21- $\frac{3}{4}$ " Wide)	
14	M320624036	2	Half Trailing Board 12"-16" Heads (8- $\frac{3}{4}$ " Wide)	
	M320624038	2	Half Trailing Board 18"-22" Heads (11- $\frac{3}{4}$ " Wide)	
	M320624040	2	Half Trailing Board 24"-32" Heads (16- $\frac{5}{8}$ " Wide)	
15	M320070003	1	Extension Shield for Heads > 32"; (optional)	
	M520050008	1	Shield Set Complete for 12"-16" Heads	Contains everything above <i>except</i> for Extension Shields
	M520050009	1	Shield Set Complete for 18"-22" Heads	
	M520050010	1	Shield Set Complete for 24"-32" Heads	

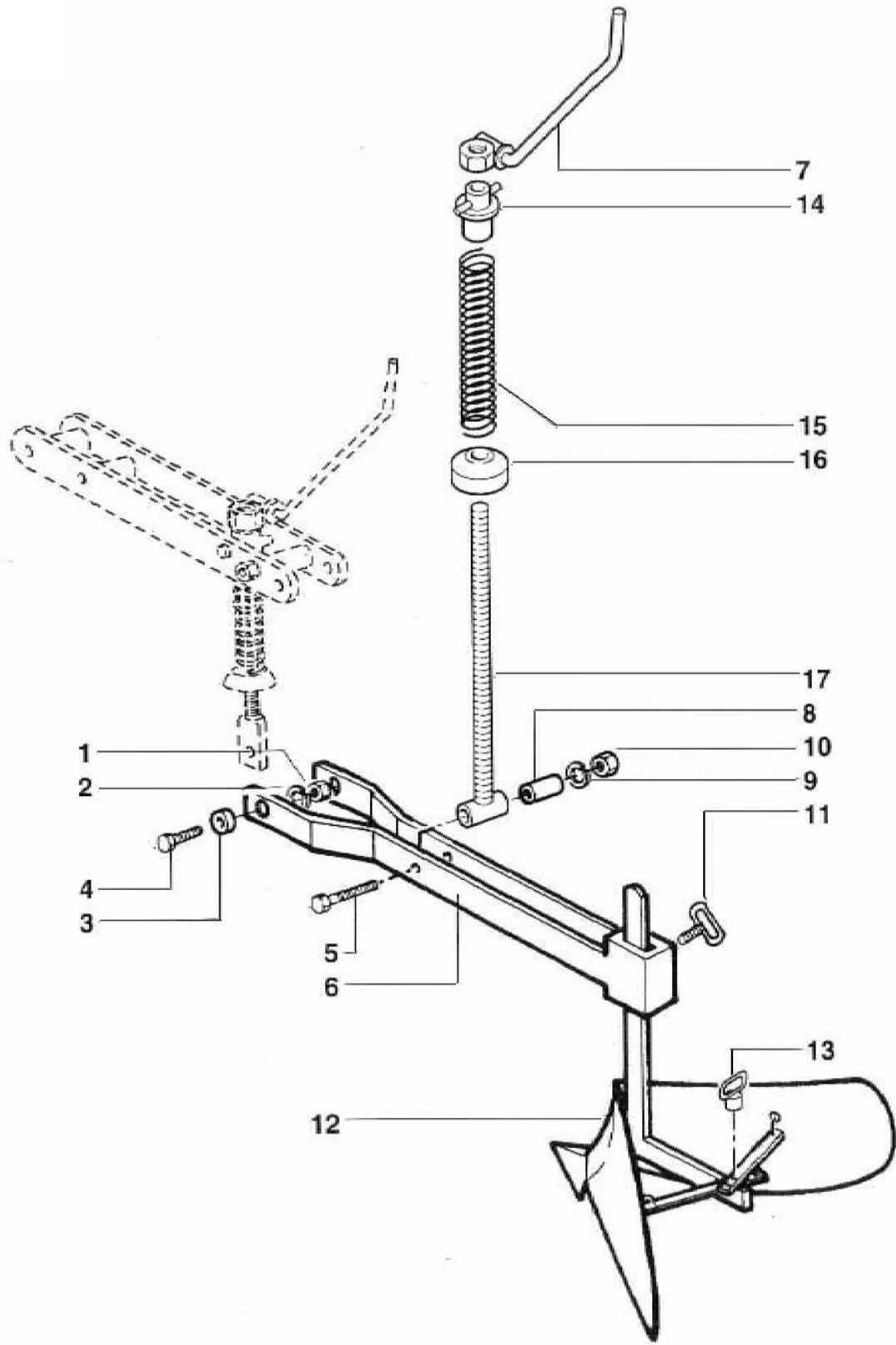

FPSR RIDGER ASSEMBLY

FPSR RIDGER ASSEMBLY

No	Part Number	Qty	Description
1	M103040022	2	Nut M10
2	M103100010	2	Washer M10
3	M330090002	2	Bushing
4	M103150072	2	Bolt M12 x 35 x 1.75 Plated
5	M103150090	1	Bolt M12 x 90 x 1.75 Plated
6	M440090006	1	Ridger Bracket Arm / FPSR
	M440090008	1	Ridger Bracket Arm / FPSRXA
7	M520130003	1	Handle with Nut
8	M320210012	1	Spacer
9	M103100010	1	Washer M12
10	M103040022	1	Nut M10
11	M440270001	1	Ridger Bolt
12	M500230001	1	Ridger Spade
13	M440270002	1	Ridger Nut
14	M420490003	1	Spring Guide / FPSR
15	M320470004	1	Spring Coil / FPSR
16	M420120003	1	Spring Collar / FPSR
17	M440680003	1	Threaded Rod / FPSR
	M440680004	1	Threaded Rod / FPSRXA
	M330590001	1	Weld On Point
	M330030001	1	Weld on Wear Strip
	M330040026	2	Pin for Ridger Spade

Not Shown

M540230008	Ridger Assembly / FPSR	Contains everything shown above
M540230010	Ridger Assembly / FPSRXA	

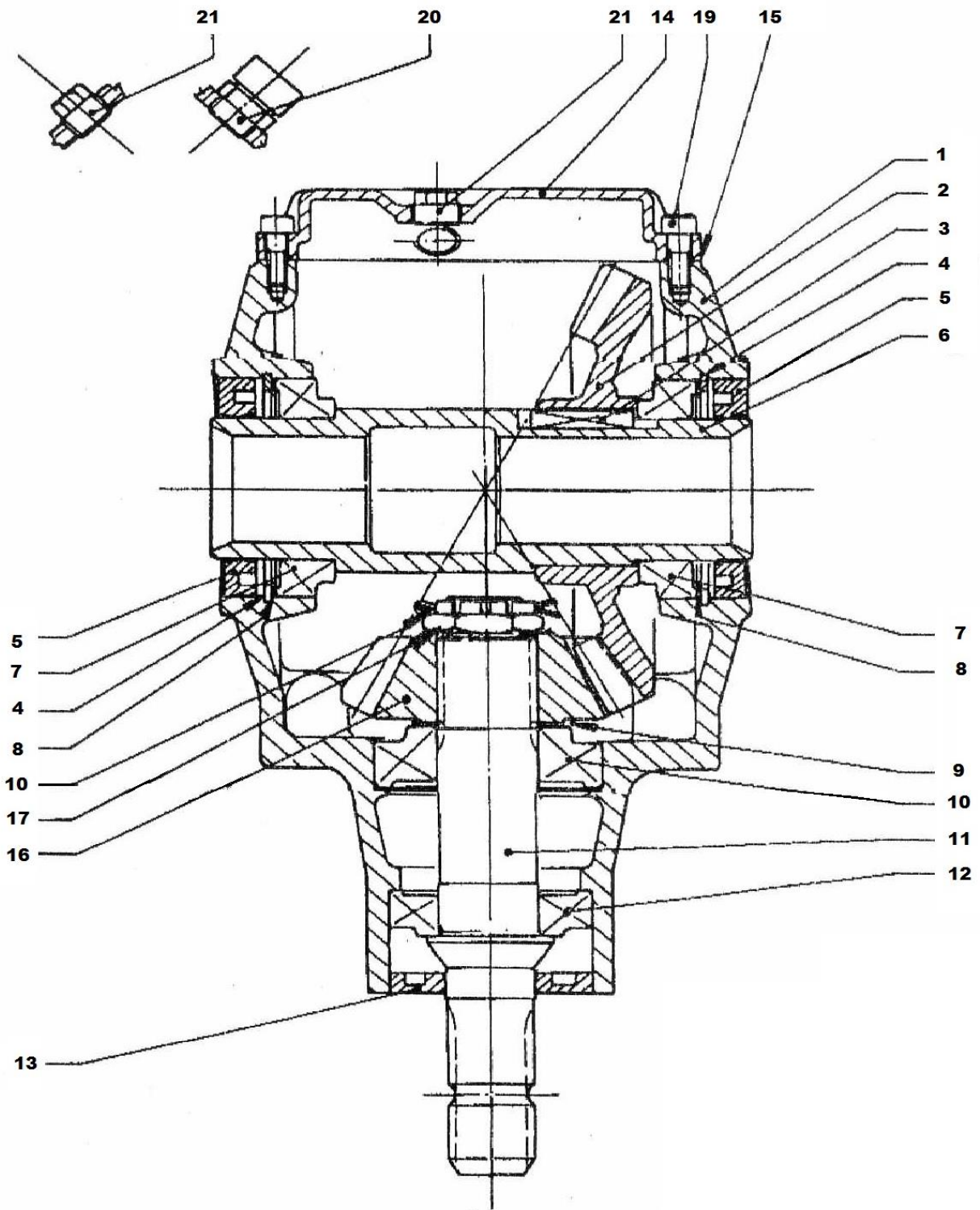

FPSR 540 RPM Gearbox

FPSR 540 RPM GEARBOX

No	Part Number	Qty	Description
1	M02620301	1	Gearbox Housing
2	M02626003	1	Crownwheel 29 Teeth
3	M84100978	1	Key 14 x 9 x 40
4	M85200123	2	Snapping Internal 100mm
5	M87300948	2	Oilseal 100 x 65 x 10
6	M02623001	1	Hex Sleeve 50mm
7	M80900976	2	Bearing 32013
8	M07037500	2	Shim
9	M02447500	1	Shim
10	M80900128	1	Bearing 30308
11	M02622000	1	Input Shaft
12	M80900024	1	Bearing 30208
13	M87300027	1	Oilseal 80 x 40 x 10
14	M82500064	1	Ring Nut M40 x 1.5
15	M83800065	1	Tab Washer 40 x 62 x1.25
16	M02625000	1	Pinion Gear 15 Teeth
17	M02597525	1	Shim
18	M82500917	1	Ring Nut M35 x 1.5
19	M81200197	6	Bolt M8 x 25 (Socket Head)
20	M86700269	1	Breather Plug
21	M86500203	2	Plug
22	M02621302	1	Rear Cover

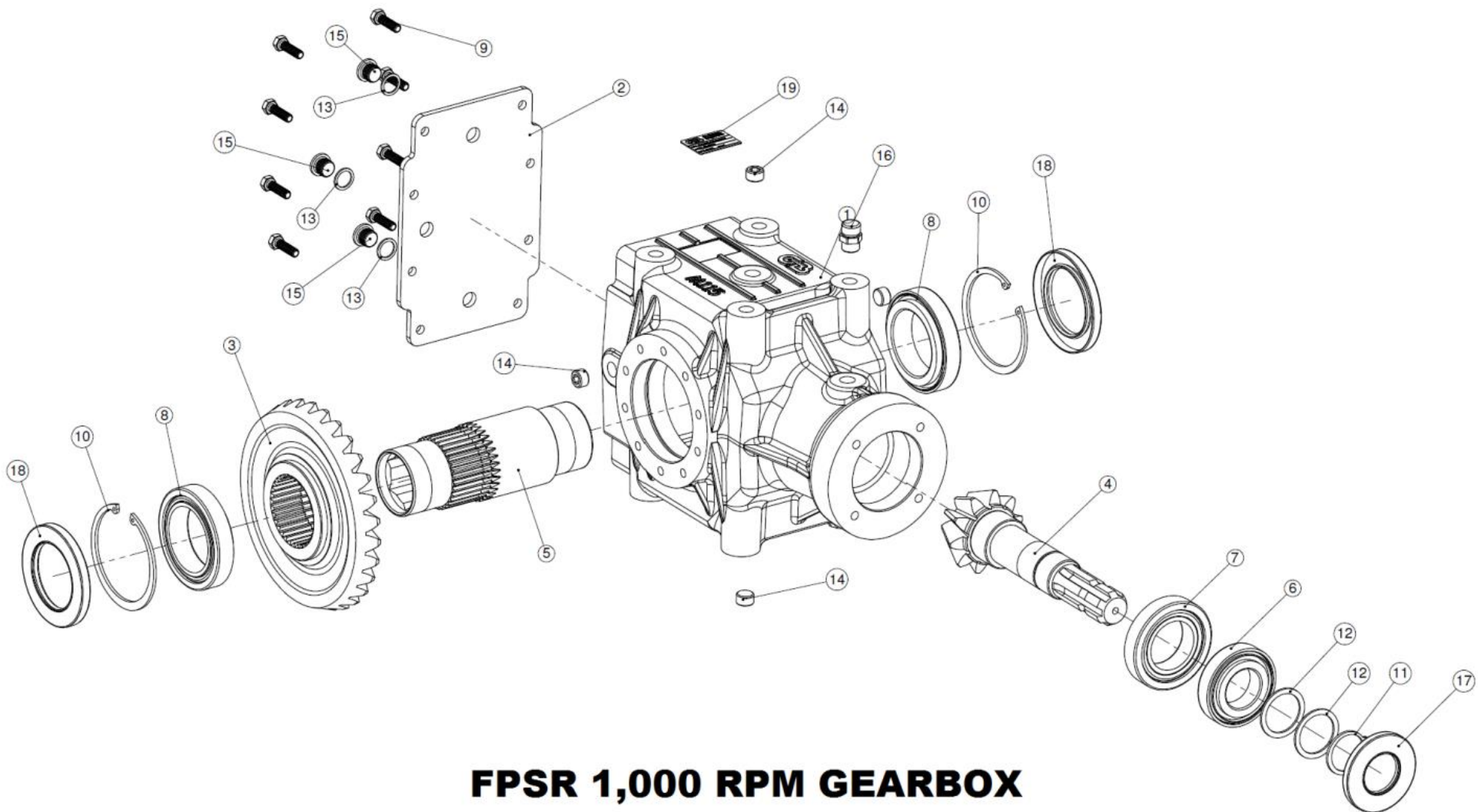

FPSR 1,000 RPM GEARBOX

FPSR 1,000 RPM GEARBOX

No	Part Number	Qty	Description
1	M01105LF006	1	Gearbox housing
2	M0210500405	1	Back Cover
3	M03106300C0	1	Crownwheel 30 Teeth
4	M04105300P1	1	Input Shaft
5	M0510600200	1	Sleeve 50mm
6	M80900024	1	Bearing 30208
7	M80900469	1	Bearing 30210
8	M80900469	2	Bearing 32013
9	M103140026	8	Bolt M8 x 30 10.9
10		2	Internal Snpring UNI 7437 - 100
11		1	External Snpring UNI7436 - 40
12		2	Shim DIN 988 40 x 50 x 2
13		3	Copper Gasket 3/8" plug
14		4	3/8" Oil Cap DIN 906 Zinc
15		3	3/8" Oil Cap DIN 908 Galvanized
16		1	3/8" Tapered Breather Valve; Brass
17		1	Oilseal 40 x 80 x 8
18		2	Oilseal 65 x 100 x 10
19		1	ID Plate

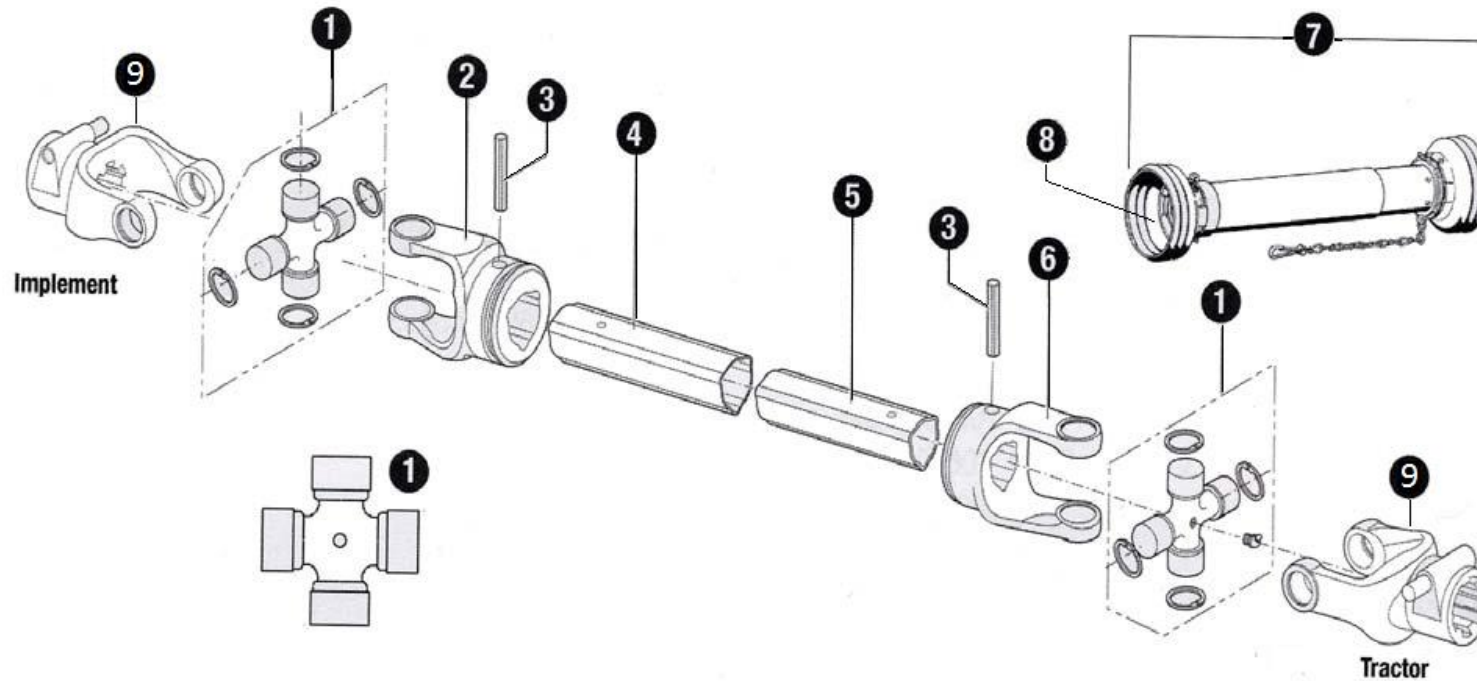

PTO SHAFT ASSEMBLY 66" – 192" FRAMES			
No	Part Number	Qty	Description
1	200-8692	2	Cross and bearing kit
2	700-6654	1	Yoke-outer tube
3	508-1040	2	Roll pin
4	600-6654	1	Outer tube
5	400-6545	1	Inner tube
6	300-6645	1	Yoke-inner tube
7	902-3548	1	Complete PTO guard
8	961-3567	1	Guard Bearing Kit
9	102-8606*	2	Yoke 540 RPM
	560-8606†	1	Slip Clutch†

14106654	PTO Assembly with Slip Clutch	Contains everything listed above
----------	-------------------------------	----------------------------------

*Replaceable with 807-8606 (clamp yoke) for Implement end only

† Cannot order individual parts; Order entire clutch

PTO SHAFT ASSEMBLY 240" FRAMES			
No	Part Number	Qty	Description
1	200-6806	2	Cross and bearing kit
2	700-6863	1	Yoke-outer tube
3	508-1280	2	Roll pin
4	600-6863	1	Outer tube
5	600-6654	1	Inner tube
6	300-6854	1	Yoke-inner tube
7	900-4548	1	Complete PTO guard
8	961-4589	1	Guard Bearing Kit
9	102-6806*	2	Yoke 540 RPM
	563-6806†	1	Slip Clutch†

14106840	PTO Assembly with Slip Clutch	Contains everything listed above
----------	-------------------------------	----------------------------------

*Replaceable with 807-6806 (clamp yoke) for Implement end only

† Cannot order individual parts; Order entire clutch